



MODBUS for maMoS analyser
manual v.1.7.7
2020-02

1.	Basic connection data	3
2.	General information about modbus	3
3.	Modbus connection	4
4.	Types of data available via modbus:	4
5.	Mamos modbus address codes	6
5.1.	Coils (1000 code series).....	6
5.2.	Discrete inputs (2000 code series)	8
5.3.	Holding registers (3000 code series)	15
5.4.	Input registers (4000 code series)	17
5.5.	Additional tables	26
a)	Type code table for results presented on analyser's LCD	26
b)	X,Y, and Z (LSB)	27
c)	Unit type code table for results presented on analyser's LCD	28
5.6.	Modbus and Siemens SIMATIC S7-1200 (CPU1211C)	29
6.	Exception codes.....	29
7.	Connections inside mamos analyser.....	31
8.	Relays inside mamos analyser.....	33
9.	Access to connections inside mamos NDIR sensor chamber.....	33

1. Basic connection data

Default analysers modbus address: 123

Modbus connection standards: RS-485, RTU, 9600/8-E-1

2. General information about modbus

Modbus is a serial communication protocol.

Modbus works based on master-slave relation between devices connected in the network, with one master device and all others working as slaves. Master is the only device that can ask questions, while all slaves can only answer. mamos works in slave mode.

The most popular communication format is RTU (Remote terminal unit).

Command in RTU format from master to slave	Answer message in RTU format from slave to master
START BREAK minimum of 3.5 x time for single character transmission	START BREAK minimum of 3.5 × time for single character transmission
ADDRESS of the receiver 1 byte value 0-240	ADDRESS of the slave device 1 byte value 0-240
FUNCTION CODE 1 byte indicates the function code	FUNCTION CODE 1 byte indicates the function code
DATA REGION n x 1 byte	DATA REGION n × 1 byte
CRC (checksum) 2 bytes	DATA n × 1 byte
END BREAK minimum of 3.5 x time for single character transmission	CRC (checksum) 2 bytes
	END BREAK minimum of 3.5 × time for single character transmission

Maximal length of communicate (with address and CRC) – 256 bytes (**for mamos 128 bytes only**)

Silence longer than 1.5 characters resets the incoming buffer.

3. Modbus connection

Modbus terminal is positioned at the bottom of mamos, on the left side of the bottom panel.

Connection specifications

Default analysers modbus address: 123

Hardware standard: RS-485

Frame format: RTU

Bit rate: 9600 bps

Data bits: 8

Parity bit type: E

Stop bits: 1

Modbus terminal:

Socket: MCV 1,5/ 2-GF-5,08

Plug: MC 1,5/2-ST1F-5.08

A pin (TxD-/RxD-): inverting pin

B pin (TxD+/RxD+): non-inverting pin

Modbus terminal at the bottom of mamos casing.

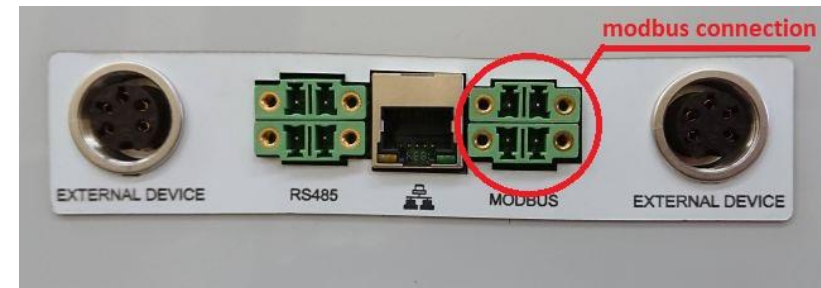

4. Types of data available via modbus:

Types of data available via modbus

Coils (single bit)

read/write

command code: 1 (read coil status)/5 (force single coil)

addresses: 1001-1008 (1004-1008 - introduced in LCD firmware ver. 5.1)

Discrete Input (single bit)

read only

command code 2 (read input status)

addresses: 2001-2100 (2040 - introduced in LCD firmware ver. 1.7, 2041-2100 - introduced in LCD firmware ver. 5.1)

Holding registers (16-bit word)

read/write

command code: 3 (read holding register)/6 (preset single register)

addresses: 3001-3016 (3016 - introduced in LCD firmware ver. 4.1)

Input registers (16-bit word)

read only

command code: 4 (read input register)

Addresses: 4001-4084 (4041-4052 - introduced in LCD driver ver. 1.7, 4053-4084 - introduced in LCD driver ver. 6.0)

Maximal length of a message (with address and CRC) for mamos analyser is **128 bytes**.

5. Mamos modbus address codes

5.1.Coils (1000 code series)

This read/write one bit data is available via modbus under these codes:

READ COILS **Command: 1**

WRITE SINGLE COIL **Command: 5**

Address	Name	Alt Name	Description
1001	COIL1	Relay4	Open drain output User programmable switch, available on outputs socket board See page 31, 33 for details Max 30VDC, 1A
1002	COIL2	Vacat2	Open drain output Vacat 2 When switched on/off connects/disconnects from ground (GND) Allows for relays connection See page 33 for details Max 30VDC, 1A
1003	COIL3	Vacat3	Open drain output Vacat 3 When switched on/off connects/disconnects from ground (GND) Allows for relays connection See page 33 for details Max 30VDC, 1A

Address	Name	Alt Name		Description
1004	COIL4	MasterOnBus	0/1 = slave/master	0/1 = slave/master
1005	COIL5	Checking1	Checking1 mode request	Checking1 mode request
1006	COIL6	Checking2	Checking2 mode request	Checking2 mode request
1007	COIL7	StartCycle	Starts measurement cycle from Zeroing phase	Starts measurement cycle from Zeroing phase
1008	COIL8	TerminateCycle	Terminates measurement cycle and goes to BeforeStandby phase	Terminates measurement cycle and goes to BeforeStandby phase

5.2. Discrete inputs (2000 code series)

This read only one bit data is available via modbus under these codes:

READ DISCRETE INPUT

Command: 2

Address prefix for PLC	Name	Alt Name	Description
2001 12001*	DI1	Relay1	Relay1 control; Hi=ON
			<p>Relays are mamos optional equipment (not present in every device)</p> <p>Relay is controlled and switched by mamos</p> <p>Connection with +12 DC power</p> <p>Open drain type</p> <p>For details see photo on page 31, 33</p> <p>When OFF: pins 2 and 3 are connected</p> <p>When ON: pins 1 and 2 are connected</p>
2002 12002*	DI2	Relay2	Relay2 control; Hi=ON
			<p>Relays are mamos optional equipment (not present in every device)</p> <p>Relay is controlled and switched by mamos</p> <p>Connection with +12 DC power</p> <p>Open drain type</p> <p>For details see photo on page 31, 33</p> <p>When OFF: pins 2 and 3 are connected</p> <p>When ON: pins 1 and 2 are connected</p>
2003 12003*	DI3	Relay3	Relay3 control; Hi=ON
			<p>Open drain switch</p> <p>For details see photo on page 31, 33</p>

Address prefix for PLC	Name	Alt Name	Description
2004 12004*	DI4	Relay4	Open drain output switch; Hi=ON User programmable switch, available on outputs socket board Check page 31, 33 for details Max 30VDC, 1A
2005 12005*	DI5	Relay5	For future use, always 0 For internal use only No connections provided
2006 12006*	DI6	Relay6	
2007 12007*	DI7	Relay7	
2008 12008*	DI8	Relay8	
2009 12009*	DI9	In1	Digital input1 Digital input (located on analogue I/O board), allows to restart/ terminate mamos measurement cycle TTL levels (in relation to mamos GND), Schmitt trigger, accepts up to 24 VDC Floating = high level Connection: pin 5 in TOP ROW, REAR

Address prefix for PLC	Name	Alt Name	Description
2010 12010*	DI10	In2	Digital input2
2011 12011*	DI11	In3	Digital input3
2012 12012*	DI12	In4	Digital input4
2013 12013*	DI13	In5	Digital input5 dip switch status
2014 12014*	DI14	In6	Digital input6 dip switch status
2015 12015*	DI15	In7	for future use, always 0
2016 12016*	DI16	In8	for future use, always 0

Digital input (located on analogue I/O board), allows to restart/ terminate mamos measurement cycle
TTL levels (in relation to mamos GND), Schmitt trigger accepts up to 24 VDC
Floating = high level = 0
Connection: pin 5 in TOP ROW, FRONT and any of GND pins

For internal use only
No connections provided

Address prefix for PLC	Name	Alt Name	Description
2017 12017*	DI17	Valvell	auxiliary channel valve, status 1=ON Valve in optional AUX gas channel (provided for fragile gas sensors like H ₂ S or CO) Modes: ventilation/measurement 0=measurement
2018 12018*	DI18	PumpII	auxiliary channel pump, status 1=ON Pump for ventilation of AUX channel 0=OFF (0 = measurement in progress, ventilation pump for AUX channel not working)
2019 12019*	DI19	Fan1	Main fan for mamos case, status 1=ON Main ventilating fan for mamos case 0=OFF Positioned inside the mamos case, bottom left corner. Settings for fan available in Settings--> Stabilisation of internal temperature
2020 12020*	DI20	PeltierIn	peltier element in mamos gas dryer; status 0=ON Cooling element for mamos MD2 gas dryer, available for compact mamos with MD2 gas dryer only. FYI, MD3 gas dryer controls peltier elements at own discretion. 0=OFF
2021 12021*	DI21	Vacat2	open drain output Vacat 2 – real value When switched on connects to ground (GND) Allows for relays connection See page 33 for details
2022 12022*	DI22	Vacat3	open drain output Vacat 3 – real value When switched on connects to ground (GND) Allows for relays connection See page 33 for details
2023 12023*	DI23	Valve4PdifZeroing	Zeroing valve for differential pressure sensor Two valves coupled together for differential pressure sensor, switch between work mode (0) and calibration mode (1) 0=OFF (work mode)

Address prefix for PLC	Name	Alt Name	Description
2024 12024*	DI24	BlowBackValve	Status of probe's valve for auto ventilation purpose; status 1=ON 0=OFF
2025 12025*	DI25	PdifZeroing	Status of valve for calibration of differential pressure sensor 2 coupled valves for calibration of differential pressure sensor. 0=calibration off (differential pressure sensor is measuring)
2026 12026*	DI26	EvenCycle	Information about current source of gas sample (for mamos twin-split configuration) Mamos can work in compact, split and twin-split configurations. In twin-split configuration two gas sources can be measured (in turns). This discrete input informs from which source mamos is collecting sample. 1= EVEN, 0=ODDd
2027 12027*	DI27	EvenCycleNext	Information about next source of gas sample (for mamos twin-split configuration) Information about the source of the next measurement cycle. 1=EVEN, 0=ODD
2028 12028*	DI28	MeasureMplusA	AUX channel measurement status (M+A) AUX channel is introduced to mamos in order to protect sensitive sensors or to prolong their lifetime (e.g. CO, H ₂ S) 0=OFF (1=WORK) (0 means AUX channel is in ventilation or standby mode = sensors in AUX channel are not measuring)
2029 12029*	DI29	OverDraft	Overdraft status for latched values on analogue Values on analogue outputs are latched (on the last correct value) for the time of sensor's ventilation. Overdraft is additional time (beyond ventilation) when values are still being latched (in order to gas reach sensors after ventilation). See more information about Overdraft (Infusion) time in the user manual. 0=OFF
2030 12030*	DI30	IsMMCSlot	Datalogger status Information if the mamos is equipped with optional data-logger 0=NOT PRESENT

Address prefix for PLC	Name	Alt Name	Description	
2031 12031*	DI31	IsMMCCard	Memory card status	Status of SD card presence in mamos data-logger 0=NOT PRESENT
2032 12032*	DI32	IsAD7705	Differential pressure sensor	AD7705 is A/D converter for differential pressure sensor. It is present when differential pressure sensor is present. 0=NO PRESSURE SENSOR PRESENT
2033 12033*	DI33	IsSwitch	Mode switch status 0=not present, 1=present	Status for mamos mode switch presence 0=NO WORK MODE SWITCH PRESENT
2034 12034*	DI34	Standby	Status for Forced standby mode (in long-term working modes)	Mamos can work in long-term modes (1÷30 days). This discrete input informs if mamos is in stand-by mode 0=OFF
2035 12035*	DI35	OverPressure	Pressure exceed error (for mamos pressurised version only)	Optional, pressurised version of mamos analyser can work up to 1,8bar. This output informs when pressure limit is exceeded. 0=NO OVERPRESSURE ALARM
2036 12036*	DI36	AuxOverranged	Result that triggers AUX channels was exceeded	AUXiliary channel in mamos can be triggered with time or with the threshold result from other sensor. AUX channel can be set in mamos program: Setting available in Settings→ Auxiliary channel 0=NO OVERRANGE ALARM (AUX channel is enabled)
2037 12037*	DI37	DryerError	Dryer Error	Discrete input meaningful only for mamos with MD2 gas dryer (compact configuration) Alarm triggered if peltier cooling element does not switch ON/OFF for time longer that 60 seconds 0=NO DRYER ERROR ALARM

Address prefix for PLC	Name	Alt Name		Description
2038 12038*	DI38	FlowTooLow	Flow too low	Mamos is equipped with sensor that controls flow measurement through device. If flow drops below specified value an error is reported. Flow control threshold value can be set in mamos program: Settings-->Gas pump 0=NO FLOW TOO LOW ALARM
2039 12039*	DI39	NoActivePoints	Error control for work modes: <ul style="list-style-type: none"> Measurements triggered by a digital input Measurements according to scheduler 	One of the work modes (listed on the left) was selected, but none triggering points are selected (mamos will not start measurements at any time) 0=NO ALARM
2040 12040*	DI40	Valvel	Ventilation valve status	Informs about status of main valve for ventilation purposes 1=ON (mamos is ventilating)
2041-2100 12041-12100*	DI41- DI100	----	For future use, always 0	For internal use only No connections provided

* address with prefix for programmable logic controller (tested with Siemens S7 controller) enabling the controller to recognise data type:

- Coils – no prefix needed
- Discrete inputs – 1
- Holding registers – 4
- Input registers – 3

5.3. Holding registers (3000 code series)

This read/write two byte data is available via modbus under these codes:

READ HOLDING REGISTER **Command: 3**

WRITE SINGLE REGISTER **Command: 6**

Address prefix for PLC	Name	Alt Name		Description
3001 43001*	HR1	MBOwnAddress	Address (MSB) and Anti-address (LSB) in modbus communication	123 by default 2 bytes: MSB – (more significant byte) – device address in binary code LSB – anti-address of the device: To change the address of the analyser both Address and Anti-address must be changed, only then the analyser will accept the new address (see the below picture)
3002 43002*	HR2	ModbusPWM	PWM setting 0..65535	PWM – 16 bits (0..65535) 5V Connection in mamos: 1 in TOP ROW (REAR) – for 5V
3003 43003*	HR3	MBModeChange	Work mode	Actual work mode of the analyser
3004 – 3013 43004-43013*	HR3 - HR15	----	for future use	Internal use only No connections provided
3014 43014*	HR14	DeviceLEDMask	LED and buzzer ON/OFF	Enable (1) or disable (0) LED and buzzer

Address prefix for PLC	Name	Alt Name		Description
3015 43015*	HR15	Device4Display	Brand	Device type on LCD
3016 43016*	HR16	ModbusCoils	Reserved!	Reserved!

Address and anti-address coding in binary system.

123 address in decimal system
01111011 address in binary system
↓ ↓ ↓ ↓ ↓ ↓ ↓ ↓
10000100 anti-address in binary system

5.4. Input registers (4000 code series)

This read only two byte data is available via modbus under these codes:

READ INPUT REGISTERS **Command: 4**

Address prefix for PLC	Name	Alt Name	Description
4001 34001*	IR1	MBResult0	#1LCD measurement result, 2 bytes, Integer U2 Result from measurement assigned to #1LCD 2 bytes Setting available in Settings-->Displays
4002 34002*	IR2	MBResult1	#2LCD measurement result, 2 bytes, Integer U2 Result from measurement assigned to #2LCD 2 bytes Setting available in Settings-->Displays
4003 34003*	IR3	MBResult2	#3LCD measurement result, 2 bytes, Integer U2 Result from measurement assigned to #3LCD 2 bytes Setting available in Settings-->Displays
4004 34004*	IR4	MBResult3	#4LCD measurement result, 2 bytes, Integer U2 Result from measurement assigned to #4LCD 2 bytes Setting available in Settings-->Displays
4005 34005*	IR5	MBResult4	#5LCD measurement result, 2 bytes, Integer U2 Result from measurement assigned to #5LCD 2 bytes Setting available in Settings-->Displays
4006 34006*	IR6	MBResult5	#6LCD measurement result, 2 bytes, Integer U2 Result from measurement assigned to #6LCD 2 bytes Setting available in Settings-->Displays
4007 34007*	IR7	MBResult6	#7LCD measurement result, 2 bytes, Integer U2 Result from measurement assigned to #7LCD 2 bytes Setting available in Settings-->Displays

Address prefix for PLC	Name	Alt Name	Description
4008 34008*	IR8	MBResult7	#8LCD measurement result, 2 bytes, Integer U2 Result from measurement assigned to #8LCD 2 bytes Setting available in Settings-->Displays
4009 34009*	IR9	MBResultCode0	#1 LCD result code type Code for result type of measurement in #1LCD (type code description in a table below)
4010 34010*	IR10	MBResultCode1	#2 LCD result code type Code for result type of measurement in #2LCD (type code description in a table below)
4011 34011*	IR11	MBResultCode2	#3 LCD result code type Code for result type of measurement in #3LCD (type code description in a table below)
4012 34012*	IR12	MBResultCode3	#4 LCD result code type Code for result type of measurement in #4LCD (type code description in a table below)
4013 34013*	IR13	MBResultCode4	#5 LCD result code type Code for result type of measurement in #5LCD (type code description in a table below)
4014 34014*	IR14	MBResultCode5	#6 LCD result code type Code for result type of measurement in #6LCD (type code description in a table below)
4015 34015*	IR15	MBResultCode6	#7 LCD result code type Code for result type of measurement in #7LCD (type code description in a table below)
4016 34016*	IR16	MBResultCode7	#8 LCD result code type Code for result type of measurement in #8LCD (type code description in a table below)
4017 34017*	IR17	MBUnitDP0	Unit code (MS byte) and precision point (LS byte) for result in #1 LCD Unit code (MS byte) and precision point (LS byte) for result in #1 LCD (unit type code description in tables below)

Address prefix for PLC	Name	Alt Name	Description	
4018 34018*	IR18	MBUnitDP1	Unit code (MS byte) and precision point (LS byte) for result in #2 LCD	Unit code (MS byte) and precision point (LS byte) for result in #2 LCD (unit type code description in tables below)
4019 34019*	IR19	MBUnitDP2	Unit code (MS byte) and precision point (LS byte) for result in #3 LCD	Unit code (MS byte) and precision point (LS byte) for result in #3 LCD (unit type code description in tables below)
4020 34020*	IR20	MBUnitDP3	Unit code (MS byte) and precision point (LS byte) for result in #4 LCD	Unit code (MS byte) and precision point (LS byte) for result in #4 LCD (unit type code description in tables below)
4021 34021*	IR21	MBUnitDP4	Unit code (MS byte) and precision point (LS byte) for result in #5 LCD	Unit code (MS byte) and precision point (LS byte) for result in #5 LCD (unit type code description in tables below)
4022 34022*	IR22	MBUnitDP5	Unit code (MS byte) and precision point (LS byte) for result in #6 LCD	Unit code (MS byte) and precision point (LS byte) for result in #6 LCD (unit type code description in tables below)
4023 34023*	IR23	MBUnitDP6	Unit code (MS byte) and precision point (LS byte) for result in #7 LCD	Unit code (MS byte) and precision point (LS byte) for result in #7 LCD (unit type code description in tables below)
4024 34024*	IR24	MBUnitDP7	Unit code (MS byte) and precision point (LS byte) for result in #8 LCD	Unit code (MS byte) and precision point (LS byte) for result in #8 LCD (unit type code description in tables below)
4025 34025*	IR25	MBAnaoutU1	Voltage value forced in analogue output U1, 2 bytes UINT in mV	Voltage value forced in analogue output U1 2 bytes UINT in mV
4026 34026*	IR26	MBAnaoutU2	Voltage value forced in analogue output U2, 2 bytes UINT in mV	Voltage value forced in analogue output U2 2 bytes UINT in mV

Address prefix for PLC	Name	Alt Name	Description	
4027 34027*	IR27	MBAnaoutU3	Voltage value forced in analogue output U3, 2 bytes UINT in mV	Voltage value forced in analogue output U3 2 bytes UINT in mV
4028 34028*	IR28	MBAnaoutU4	Voltage value forced in analogue output U4, 2 bytes UINT in mV	Voltage value forced in analogue output U4 2 bytes UINT in mV
4029 34029*	IR29	MBAnaoutI1	Current value forced in analogue output I1, 2 bytes UINT in μ A	Current value forced in analogue output I1 2 bytes UINT in μ A
4030 34030*	IR30	MBAnaoutI2	Current value forced in analogue output I2, 2 bytes UINT in μ A	Current value forced in analogue output I2 2 bytes UINT in μ A
4031 34031*	IR31	MBAnaoutI3	Current value forced in analogue output I3, 2 bytes UINT in μ A	Current value forced in analogue output I3 2 bytes UINT in μ A
4032 34032*	IR32	MBAnaoutI4	Current value forced in analogue output I4, 2 bytes UINT in μ A	Current value forced in analogue output I4 2 bytes UINT in μ A
4033 34033*	IR33	MBAnaOutCodeU1	Code for result type in analogue output U1	Code for result type of measurement in analogue output U1 (type code description in a table below)
4034 34034*	IR34	MBAnaOutCodeU2	Code for result type in analogue output U2	Code for result type of measurement in analogue output U2
4035 34035*	IR35	MBAnaOutCodeU3	Code for result type in analogue output U3	Code for result type of measurement in analogue output U3
4036 34036*	IR36	MBAnaOutCodeU4	Code for result type in analogue output U4	Code for result type of measurement in analogue output U4
4037 34037*	IR37	MBAnaOutCodeI1	Code for result type in analogue output I1	Code for result type of measurement in analogue output I1
4038 34038*	IR38	MBAnaOutCodeI2	Code for result type in analogue output I2	Code for result type of measurement in analogue output I2

Address prefix for PLC	Name	Alt Name		Description
4039 34039*	IR39	MBAnaOutCodeI3	Code for result type in analogue output I3	Code for result type of measurement in analogue output I3
4040 34040*	IR40	MBAnaOutCodeI4	Code for result type in analogue output I4	Code for result type of measurement in analogue output I4
4041 34041*	IR41	MamosMode	Information about selected work mode	000H – manual (mode triggered with work knob) 055H – according to scheduler 05AH – Triggered by digital inputs 0A5H – Cyclic work mode 0B0H – Monthly-cyclic mode 0B1H – Monthly-cyclic mode with adjustable length (1-30 days)
4042 34042*	IR42	MamosStatus	Information about current phase of mamos work	0 – Warming 1 – Zeroing 2 – Measuring 3 – Initial phase of standby (purging of gas path) 4 – Standby 5 – Display test 6 – Display identification 7 – The first zeroing (after warming) 8 – Initial phase of measurements (infusion of gas)
4043 34043*	IR43	SDStatus	Status concerning SD card and data-logging	0 – no card present 1 – card present, storage OFF 2 – card present, storage ON 3 – card present, finishing data-logging 4 – card present, data-logging withhold 5 – card present, initialisation 6 – card present, error occurred 7 – formatting of SD card

Address prefix for PLC	Name	Alt Name	Description	
				Single configuration 0 – Auto 1 – Measurements 2 – Zeroing 3 – Standby 4 – Service 6 – Measurements A+AUX
				Twin split configuration 0 – Auto 1 – Measurements A 2 – Zeroing 3 – Standby 4 – Service 5 – Measurements B 6 – Measurements A+AUX 7 – Measurements B+AUX
4044 34044*	IR44	SwitchPosition	Determines the position of work knob	
4045 34045*	IR45	Hour		Hour BCD 00hh
4046 34046*	IR46	MinSec		Minute and second BCD mmss
				Date and time in mamos
4047 34047*	IR47	Year		Year BCD YYYY
4048 34048*	IR48	MonthDay		Month and day BCD MMDD
4049 34049*	IR49	NextZeroHour		Hour BCD 00hh
4050 34050*	IR50	NextZeroMinSec		Minute and second BCD mmss
				Date and time of the next zeroing
4051 34051*	IR51	NextZeroYear		Year BCD YYYY
4052 34052*	IR52	NextZeroMonthDay		Month and day BCD MMDD

Address prefix for PLC	Name	Alt Name	Description	
4053 34053*	IR53	MBGasChannel	Connected gas channel on multiplexer	Connected gas channel on multiplexer
4054-4060 34054-34060*	IR54-IR60	----	For future use, always 0	Internal use only No connections provided
4061 34061*	IR61	MBResult8	#8LCD measurement result, 2 bytes, Integer U2	Result from measurement assigned to #8LCD 2 bytes Setting available in Settings-->Displays
4062 34062*	IR62	MBResult9	#9LCD measurement result, 2 bytes, Integer U2	Result from measurement assigned to #9LCD 2 bytes Setting available in Settings-->Displays
4063 34063*	IR63	MBResult10	#10LCD measurement result, 2 bytes, Integer U2	Result from measurement assigned to #10LCD 2 bytes Setting available in Settings-->Displays
4064 34064*	IR64	MBResult11	#11LCD measurement result, 2 bytes, Integer U2	Result from measurement assigned to #11LCD 2 bytes Setting available in Settings-->Displays
4065 34065*	IR65	MBResult12	#12LCD measurement result, 2 bytes, Integer U2	Result from measurement assigned to #12LCD 2 bytes Setting available in Settings-->Displays
4066 34066*	IR66	MBResult13	#13LCD measurement result, 2 bytes, Integer U2	Result from measurement assigned to #13LCD 2 bytes Setting available in Settings-->Displays
4067 34067*	IR67	MBResult14	#14LCD measurement result, 2 bytes, Integer U2	Result from measurement assigned to #14LCD 2 bytes Setting available in Settings-->Displays

Address prefix for PLC	Name	Alt Name	Description
4068 34068*	IR68	MBResult15	#15LCD measurement result, 2 bytes, Integer U2 Result from measurement assigned to #15LCD 2 bytes Setting available in Settings-->Displays
4069 34069*	IR69	MBResultCode8	#8 LCD result code type Code for result type of measurement in #8LCD (type code description in a table below)
4070 34070*	IR70	MBResultCode9	#9 LCD result code type Code for result type of measurement in #9LCD (type code description in a table below)
4071 34071*	IR71	MBResultCode10	#10 LCD result code type Code for result type of measurement in #10LCD (type code description in a table below)
4072 34072*	IR72	MBResultCode11	#11 LCD result code type Code for result type of measurement in #11LCD (type code description in a table below)
4073 34073*	IR73	MBResultCode12	#12 LCD result code type Code for result type of measurement in #12LCD (type code description in a table below)
4074 34074*	IR74	MBResultCode13	#13 LCD result code type Code for result type of measurement in #13LCD (type code description in a table below)
4075 34075*	IR75	MBResultCode14	#14 LCD result code type Code for result type of measurement in #14LCD (type code description in a table below)
4076 34076*	IR76	MBResultCode15	#15 LCD result code type Code for result type of measurement in #15LCD (type code description in a table below)
4077 34077*	IR77	MBUnitDP8	Unit code (MS byte) and precision point (LS byte) for result in #8 LCD Unit code (MS byte) and precision point (LS byte) for result in #8 LCD (unit type code description in tables below)

Address prefix for PLC	Name	Alt Name	Description	
4078 34078*	IR78	MBUnitDP9	Unit code (MS byte) and precision point (LS byte) for result in #9 LCD	Unit code (MS byte) and precision point (LS byte) for result in #9 LCD (unit type code description in tables below)
4079 34079*	IR79	MBUnitDP10	Unit code (MS byte) and precision point (LS byte) for result in #10 LCD	Unit code (MS byte) and precision point (LS byte) for result in #10 LCD (unit type code description in tables below)
4080 34080*	IR80	MBUnitDP11	Unit code (MS byte) and precision point (LS byte) for result in #11 LCD	Unit code (MS byte) and precision point (LS byte) for result in #11 LCD (unit type code description in tables below)
4081 34018*	IR81	MBUnitDP12	Unit code (MS byte) and precision point (LS byte) for result in #12 LCD	Unit code (MS byte) and precision point (LS byte) for result in #12 LCD (unit type code description in tables below)
4082 34082*	IR82	MBUnitDP13	Unit code (MS byte) and precision point (LS byte) for result in #13 LCD	Unit code (MS byte) and precision point (LS byte) for result in #13 LCD (unit type code description in tables below)
4083 34083*	IR83	MBUnitDP14	Unit code (MS byte) and precision point (LS byte) for result in #14 LCD	Unit code (MS byte) and precision point (LS byte) for result in #14 LCD (unit type code description in tables below)
4084 34084*	IR84	MBUnitDP15	Unit code (MS byte) and precision point (LS byte) for result in #15 LCD	Unit code (MS byte) and precision point (LS byte) for result in #15 LCD (unit type code description in tables below)
4085-4100 34085-34100*	IR85-IR100	----	For future use, always 0	Internal use only No connections provided

* address with prefix for programmable logic controller (tested with Siemens S7 controller) enabling the controller to recognise data type:

- Coils – no prefix needed
- Discrete inputs – 1
- Holding registers – 4
- Input registers – 3

5.5. Additional tables

a) Type code table for results presented on analyser's LCD

0 O ₂	10 Y (see table below)	20 PT500 T4	30 NO ₂ mg	40 UI1	BL_Null results from 50 SPI that are not recognised	60 Zrel
1 CO ₂	11 Z (see table below)	21 SL	31 NO _x mg	41 UI2	51 CH ₄ rel	61 not used
2 CH ₄	12 not used	22 Internal temperature	32 SO ₂ mg	42 UI3	52 CO rel	62 not used
3 CO	13 not used	23 Eta	33 H ₂ S mg	43 UI4	53 NO rel	63 Medium pressure - pressure of tested gas
4 NO	14 Pump flow	24 Lam	34 X mg	44 UI5	54 NO ₂ rel	
5 NO ₂	15 Ambient Pressure	25 Flow	35 Y mg	45 UI6	55 NO _x rel	
6 NO _x	16 Differential Pressure	26 Relative Humidity	36 Z mg	46 UI7	56 SO ₂ rel	
7 SO ₂	17 Ambient temperature	27 CH ₄ mg	37 not used	47 not used	57 H ₂ S rel	
8 H ₂ S	18 Gas temperature	28 CO mg	38 not used	48 not used	58 X rel	
9 X (see table below)	19 K type T3	29 NO mg	39 UI0	49 not used	59 Y rel	

b) X,Y, and Z (LSB)

Value (dec)	Sensor type
14	H2
15	NH3
16	Cl2
17	HCl
32	N2O
34	CHF3
43	VOC
44	H2 (TCD)
52	He (TCD)
58	C4H8 (VOC)

c) Unit type code table for results presented on analyser's LCD

Value	Name	Unit
0	UnitPPM	ppm
1	UnitPROCENT	%
2	UnitDEGC	°C
3	UnitDEGF	°F
4	UnitMGM3	mg/m ³
5	UnitGGJ	g/GJ
6	UnitHPA	hPa
7	UnitPA	Pa
8	UnitMMH2O	mmH ₂ O
9	UnitINH2O	inH ₂ O
10	UnitMS	m/s
11	UnitmV	mV
12	UnitV	V
13	UnitmA	mA
14	UnitA	A
15	UnitNONE	–
16	UnitGM3	g/m ³
17	UnitLPH	l/h
18	UnitUnknown	Unknown unit

5.6.Modbus and Siemens SIMATIC S7-1200 (CPU1211C)

maMos analyser was tested with Siemens controller and so, some documents are available for download from our website.

6. Exception codes

Following a request, there are 4 possible outcomes from the slave:

- The request is successfully processed by the slave and a valid response is sent.
- The request is not received by the slave therefore no response is sent.
- The request is received by the slave with a parity, CRC or LRC error.
The slave ignores the request and sends no response.
- The request is received without an error, but cannot be processed by the slave for another reason. The slave replies with an exception response.

In a normal response, the slave echoes the function code. The first sign of an exception response is that the function code is shown in the echo with its highest bit set. All function codes have 0 for their most significant bit. Therefore, setting this bit to 1 is the signal that the slave cannot process the request.

maMos supports these exception codes:

02 – Illegal data access

The data address received in the query is not an allowable address for the slave. More specifically, the combination of reference number and transfer length is invalid. For a controller with 100 registers, a request with offset 96 and length 4 would succeed, a request with offset 96 and length 5 will generate exception 02

03 – Illegal data value

A value contained in the query data field is not an allowable value for the slave. This indicates a fault in the structure of remainder of a complex request, such as that the implied length is incorrect. It specifically does NOT mean that a data item submitted for storage in a register has a value outside the expectation of the application program, since the MODBUS protocol is unaware of the significance of any particular value of any particular register.

7. Connections inside mamos analyser

Top row (rear)

1	PWM
2	RELAY 3
3	RELAY 4
4	+12V
5	Input 1
6	U1 (Voltage analogue output 1)
7	U2 (Voltage analogue output 2)
8	U3 (Voltage analogue output 3)
9	U4 (Voltage analogue output 4)
10	GND

Top row (front)

1	GND
2	GND
3	GND
4	VCC (+5VDC)
5	Input 2
6	I1 (Current analogue output 1)
7	I2 (Current analogue output 2)
8	I3 (Current analogue output 3)

TOP ROW REAR

TOP ROW FRONT

RELAYS ROW

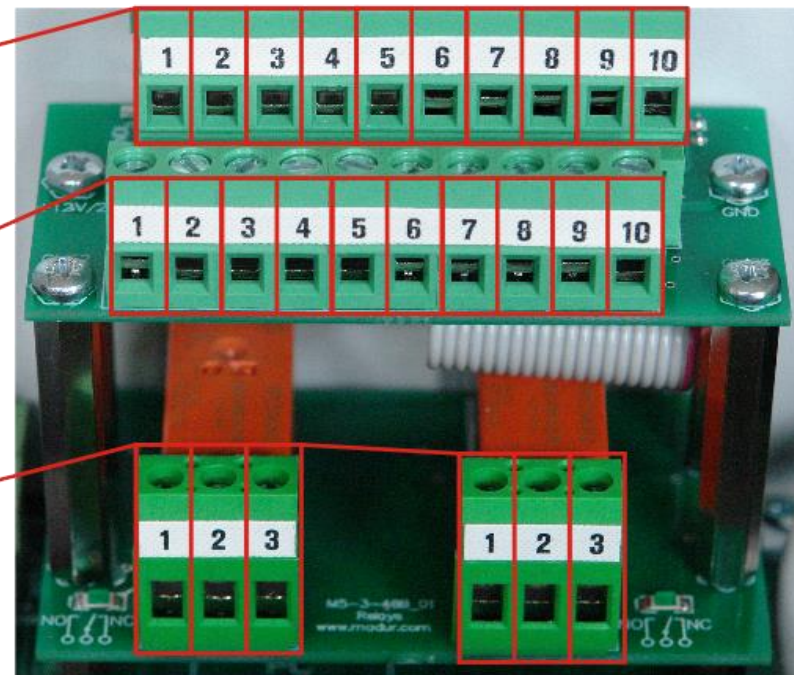

Relay 1

Relay 2

Relays inside mamos analyser.

9 I4 (Current analogue output 4)

10 GND

Relays Row (Relay 1 and relay 2)

1 Pin 1- connected to pin 2 when relay is ON

2 Pin 2 – connects to pin 1 or 3

3 Pin 3 – connected to pin 2 when relay is OFF

8. Relays inside mamos analyser

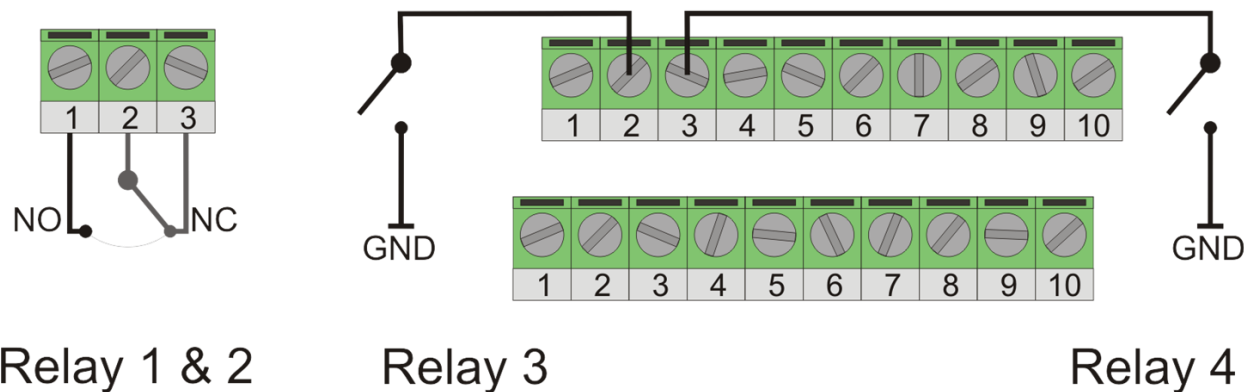

Relays inside mamos analyser.

9. Access to connections inside mamos NDIR sensor chamber

Mamos CROSS board – this part of board is available after NDIR sensor cover is removed:

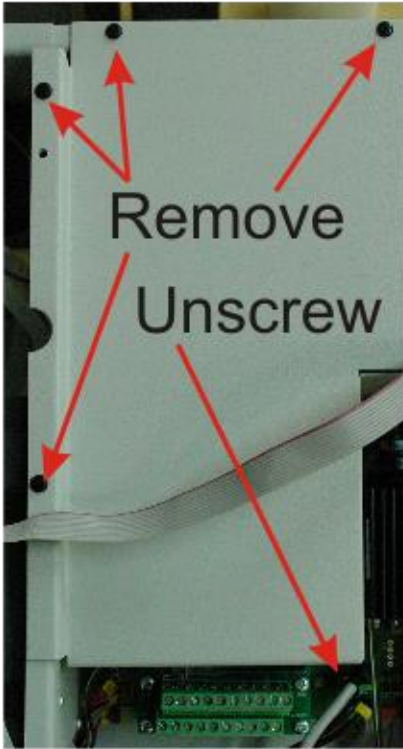

10.

NDIR sensor cover.

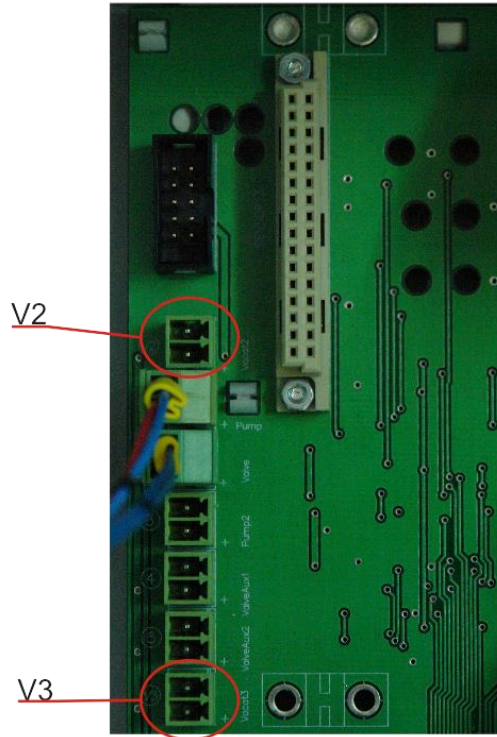

11.

Mamos cross board – vacant relays.

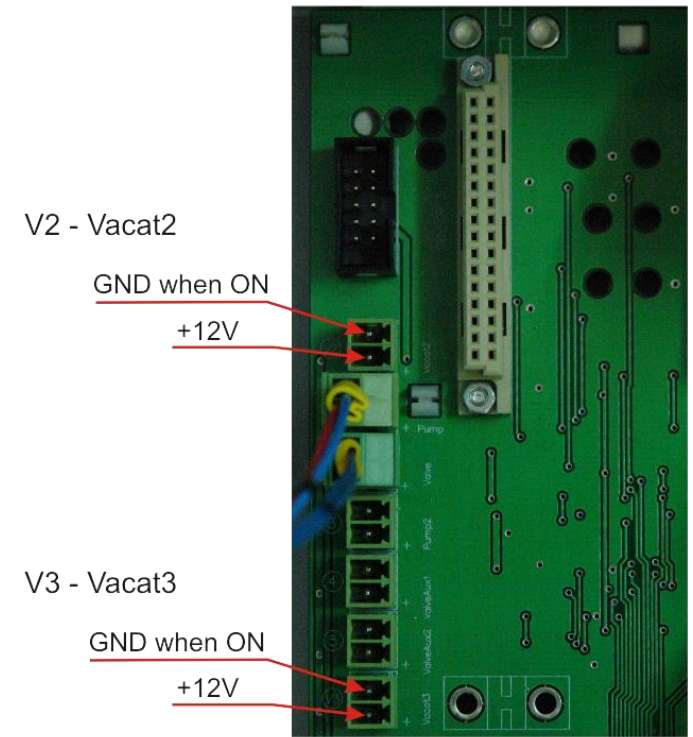

12.

Mamos cross board – vacant relays -pins.