

SENMA

INDEX

1. SENMA – INTRODUCTION.....	3
2. BLOCK DIAGRAM AND WORK PRINCIPLE.....	3
3. INSTALLATION.....	4
3.1. CONNECTORS.....	8
3.2. CONNECTING THE SENMA SENSOR.....	9
3.3. FRONT PANEL.....	9
4. SENMA PC PROGRAM.....	11
4.1. WORK CYCLES.....	12
4.2. ANALOGUE OUTPUTS.....	13
4.3. RELAY OUTPUTS (ALARMS).....	15
5. MODBUS COMMUNICATION.....	16
5.1. GENERAL PARAMETERS.....	16
5.2. TYPE OF DATA AVAILABLE VIA MODBUS.....	16
5.2.1. COILS – READ/WRITE ONE BIT DATA.....	16
5.2.2. DISCRETE INPUTS – READ-ONLY BIT DATA.....	18
5.2.3. HOLDING REGISTERS – 2-BYTE READ/WRITE DATA.....	18
5.2.4. INPUT REGISTERS – READ-ONLY 2-BYTE DATA.....	19
5.2.5. DEVICE TABLE.....	20
5.2.6. TABLE - STIMULATION SOURCE FOR RELAYS.....	20

5.2.7. RESULTS TABLE..... 21

5.2.8. SPECIAL GAS TABLE..... 22

5.2.9. UNITS TABLE..... 23

5.2.10. TABLE – WORK PHASES..... 23

5.2.11. ZEROING AND SPAN CALIBRATION VIA MODBUS..... 24

 5.2.11.1. SENSOR'S ZEROING PROCEDURE..... 24

 5.2.11.2. SPAN CALIBRATION PROCEDURE..... 24

6. TECHNICAL DATA AND OPERATIONAL INFORMATION..... 25

1. SENMA – INTRODUCTION

Senma is a single gas detector, highly adjustable to users requirements. Depending on the measured gas and/ or concentration (measurement range) it utilise various measurement techniques: NDIR (non-dispersive infrared absorption), EC (electrochemical), PID (photo-ionic detection) or TCD (thermal-conductivity detection). Every sensor is adjusted for a certain gas and calibrated at required range and measurement resolution.

Gas sample is driven with help of a built-in membrane gas pump (it is not a diffusion sensor). In case of gas detection (exceeding of a safe concentration level) Senma triggers an alarm.

2. BLOCK DIAGRAM AND WORK PRINCIPLE

Sensor works in cyclic mode, where the following phases are distinguished:

1. Warming-up – the first work phase, occurs only after the sensor is powered-on. Phase duration is 15, during which sensor prepares itself to work.
2. Stand-by (optional) – awaiting for the next measurement cycle. Stand-by occurs only if the Measurement time + Ventilation time is shorter than duration of the entire measurement cycle.
3. Ventilation (ended with Zeroing of sensor) – this phase is obligatory for sensor to work correctly. It is advised to perform zeroing at least twice a day for minimum 15 minutes.
Factory setting: duration 15 min, the first zeroing at 6.00 AM, the next one at 6.00 PM
4. Measurements – essential phase.

Sensor is equipped with electromagnetic valve that is, depending on the sensor's current work phase, either opened to measured gas (Measurement phase) or to fresh air (Ventilation). Gas (or fresh air) is sucked by sensor with help of membrane pump.

On sensor's housing there are three gas ports: gas inlet, fresh-air inlet, gas outlet.

Gas sample (from location of potential leakage) and fresh air (from source of fresh-air: outdoors, room's ventilation outlet) must be led to sensor using PTFE 4x6mm tubes.

Senma sensors, that are working with electrochemical cells, are also equipped with a special gas dumper that levels out the membrane pump's pulsatory fed of a sample – this damper eliminates oscillations of Senma's output signals = makes the result more stable.

Sensor is equipped with differential pressure sensor that controls the patency of gas path.

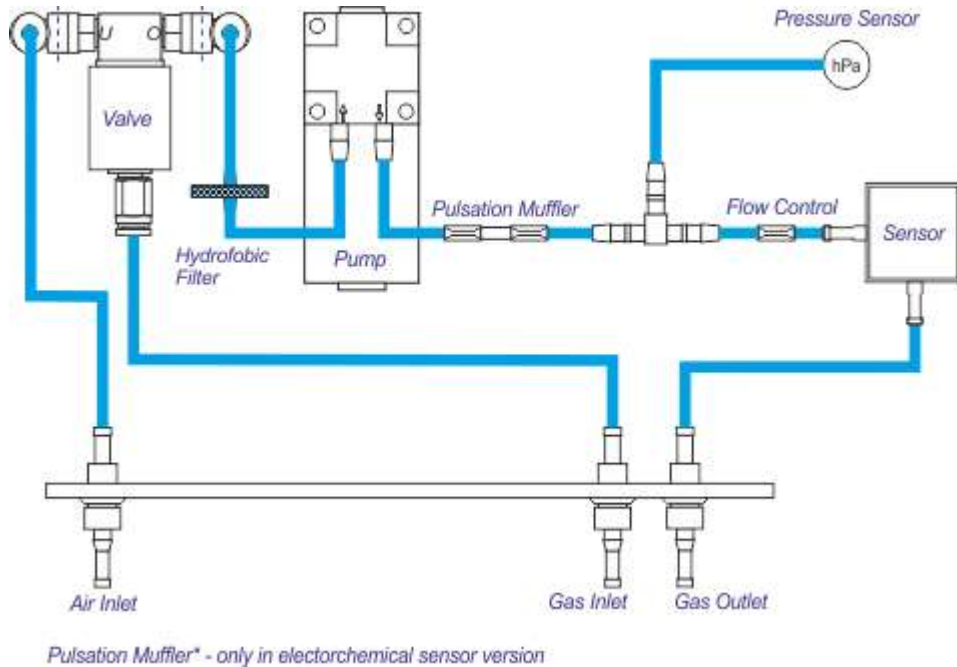

Drawing 1. Senma – block diagram

3. INSTALLATION

Sensor Senma is encapsulated in ABS housing, that allows to install sensor e.g. on a wall. Drawing 2. ÷ Drawing 4. and Drawing 6. ÷ Drawing 7. show the sensor dimensions. Drawing 5. shows how the installation bores should be prepared.

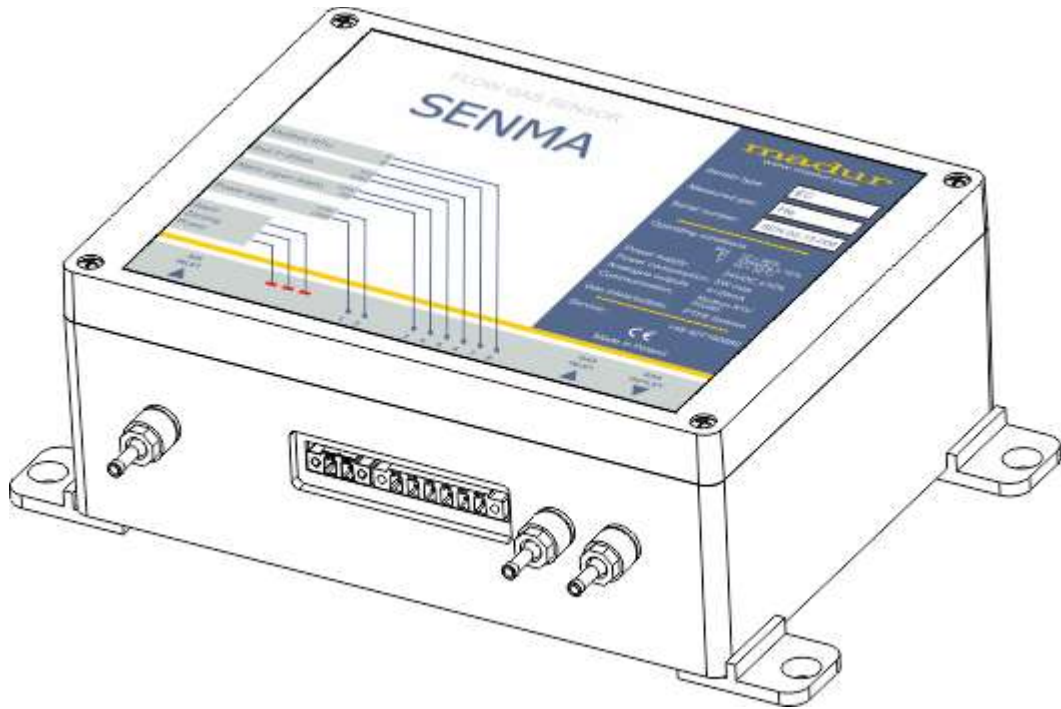

Drawing 2. Senma – isometric view

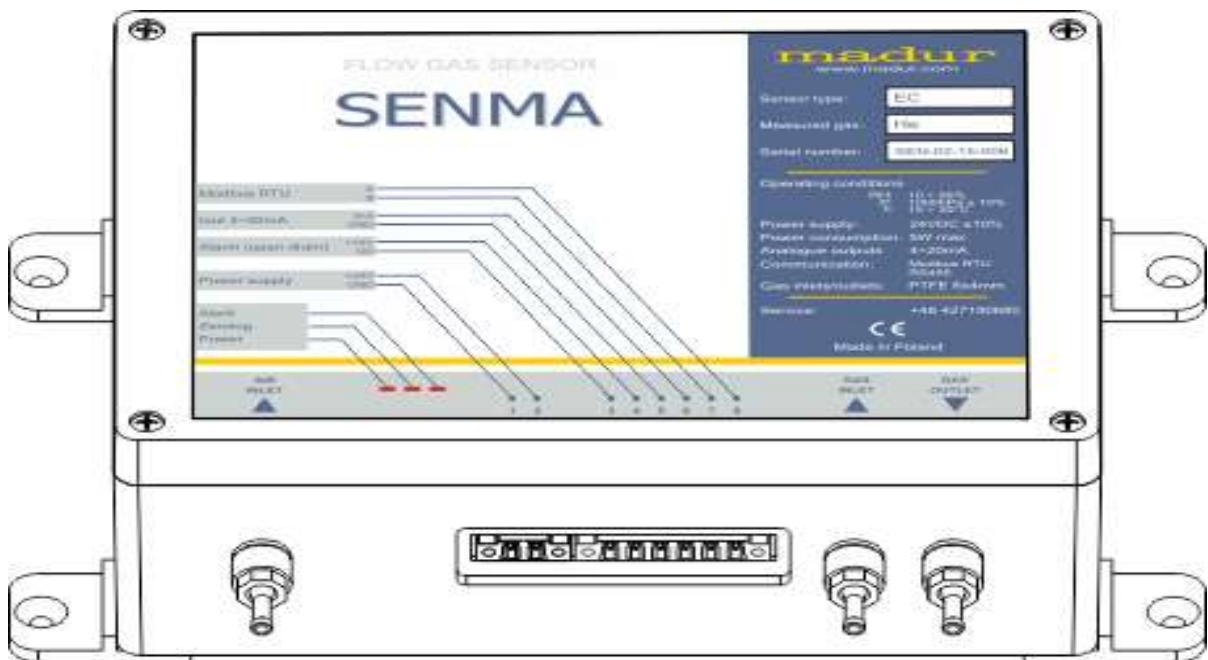

Drawing 3. Senma – view at the front panel and connectors

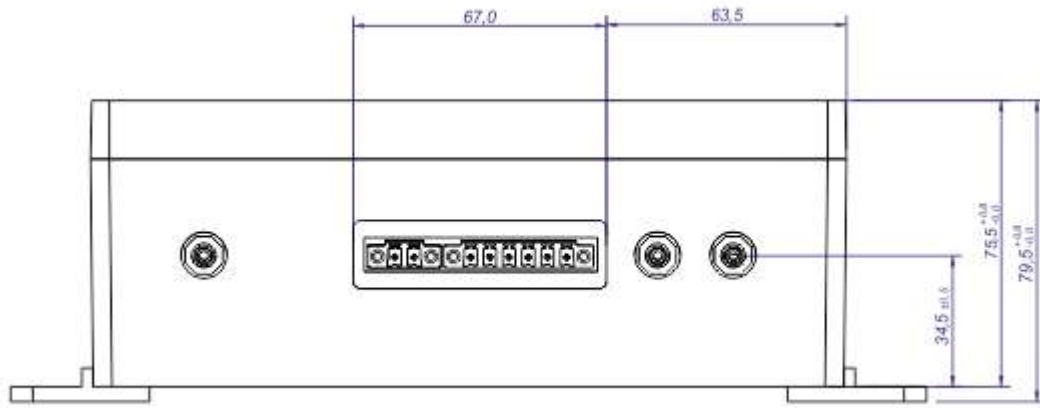

Drawing 4. Senma – view at connectors

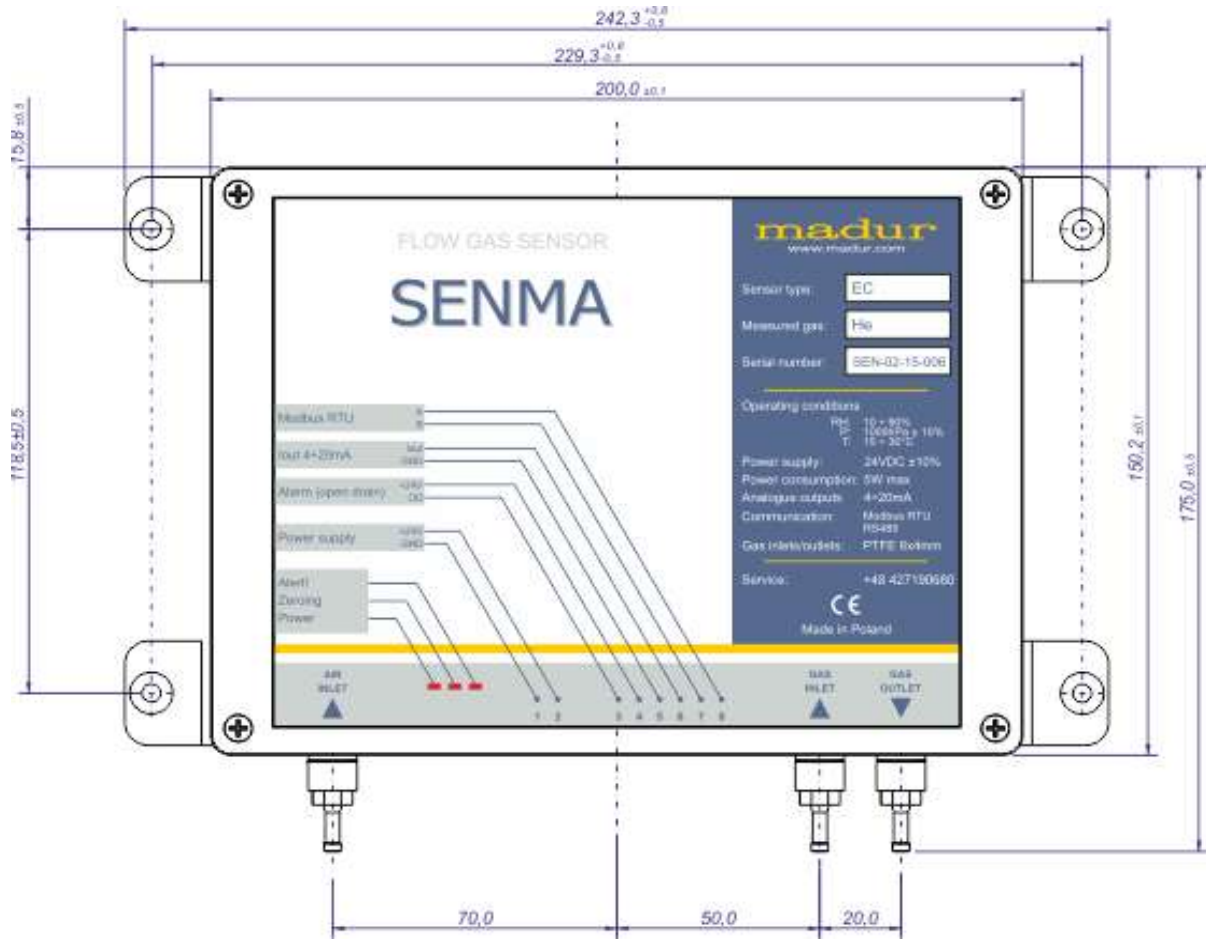

Drawing 5. Senma – view at front panel

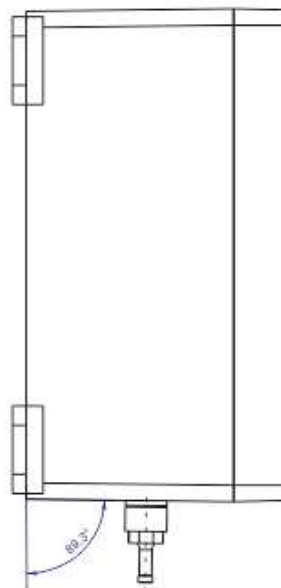

Drawing 6. Senma – side view

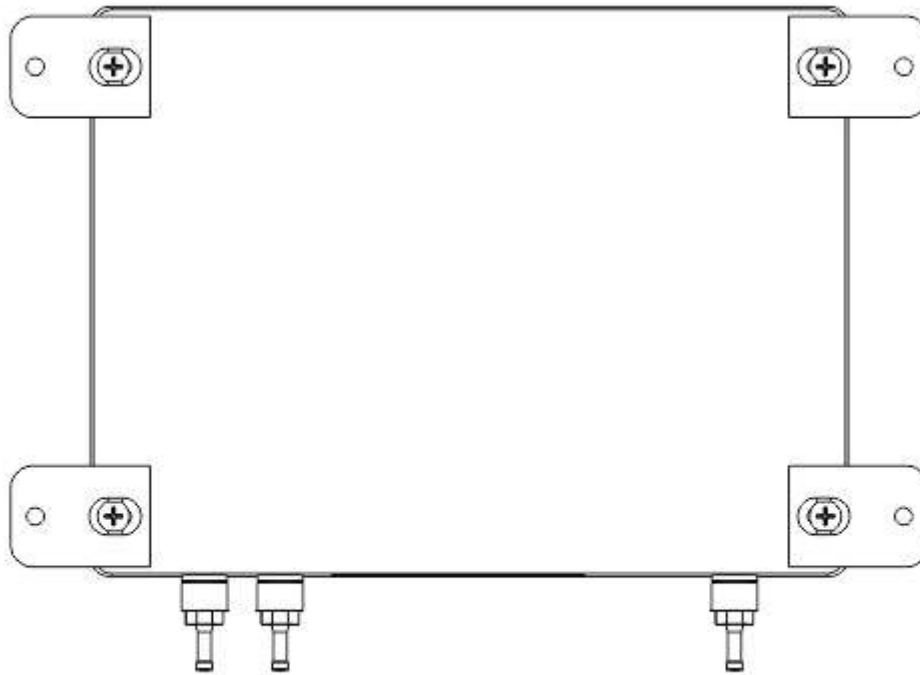

Drawing 7. Senma – view from behind

3.1. Connectors

Drawing 8. shows alle possible connectors in Senma sensor.

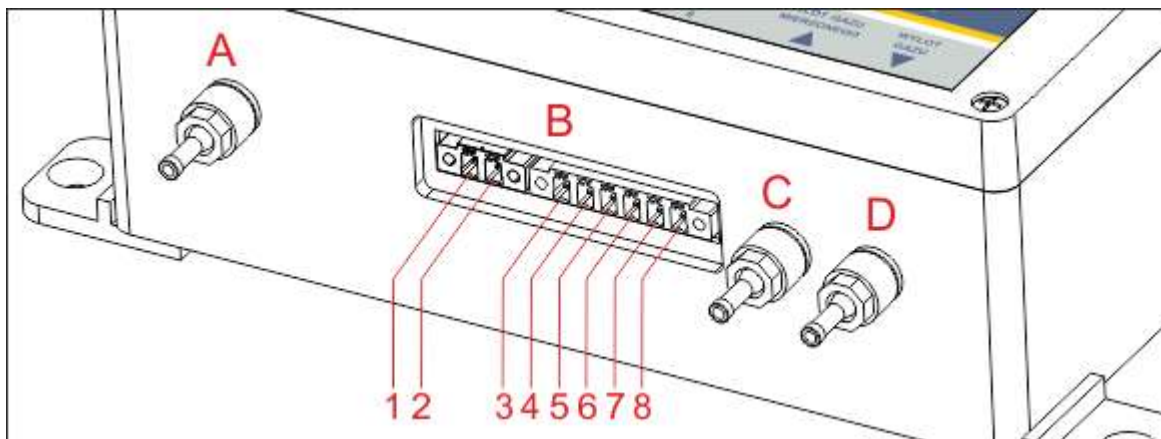

Drawing 8. Senma – view at connectors

- A. Fresh-air inlet port
- B. Electrical connector (1+2 – supply; 3+8 – communication)
 - 1. Supply GND
 - 2. Supply +24V
 - 3. Alarm (open drain) OD
 - 4. Alarm (open drain) +24V

5. Iout 4÷20mA (GND)
 6. Iout 4÷20mA (Iout)
 7. RS485 B / Modbus RTU B
 8. RS485 A / Modbus RTU A
- C. Gas inlet
D. Gas outlet

3.2. Connecting the Senma Sensor

1. After the sensor is installed in desired position, it is necessary to provide 24VDC supply and connect it according to B1 i B2
2. Connect all communication lines: current analogue output, alarm and MODBUS digital output according to Drawing 8. B3 ÷ B8.
3. Gas ports (Drawing 8. A, C and D) connect with PTFE 4x6mm (ID=4mm, OD=6mm) tube:
 - gas inlet deliver to the source of potential leakage
 - fresh-air inlet deliver to the source of neutral gas (deprived from the molecules of measured gas), e.g. to ventilation or directly from outdoors.
 - Gas outlet leave "open to surroundings".*

*REMARK! In case of Senma sensor equipped with electrochemical H₂ sensor, do not obstruct, nor connect tubing to outlet, as H₂ cell is very sensitive to pressure changes.

3.3. Front panel

Drawing 9. shows example of sensor's front panel. The sticker describes connectors (gas ports and electrical terminal), LED and provides information about sensor (type of gas, serial number, etc.) and work parameters (power supply, power consumption, etc.)

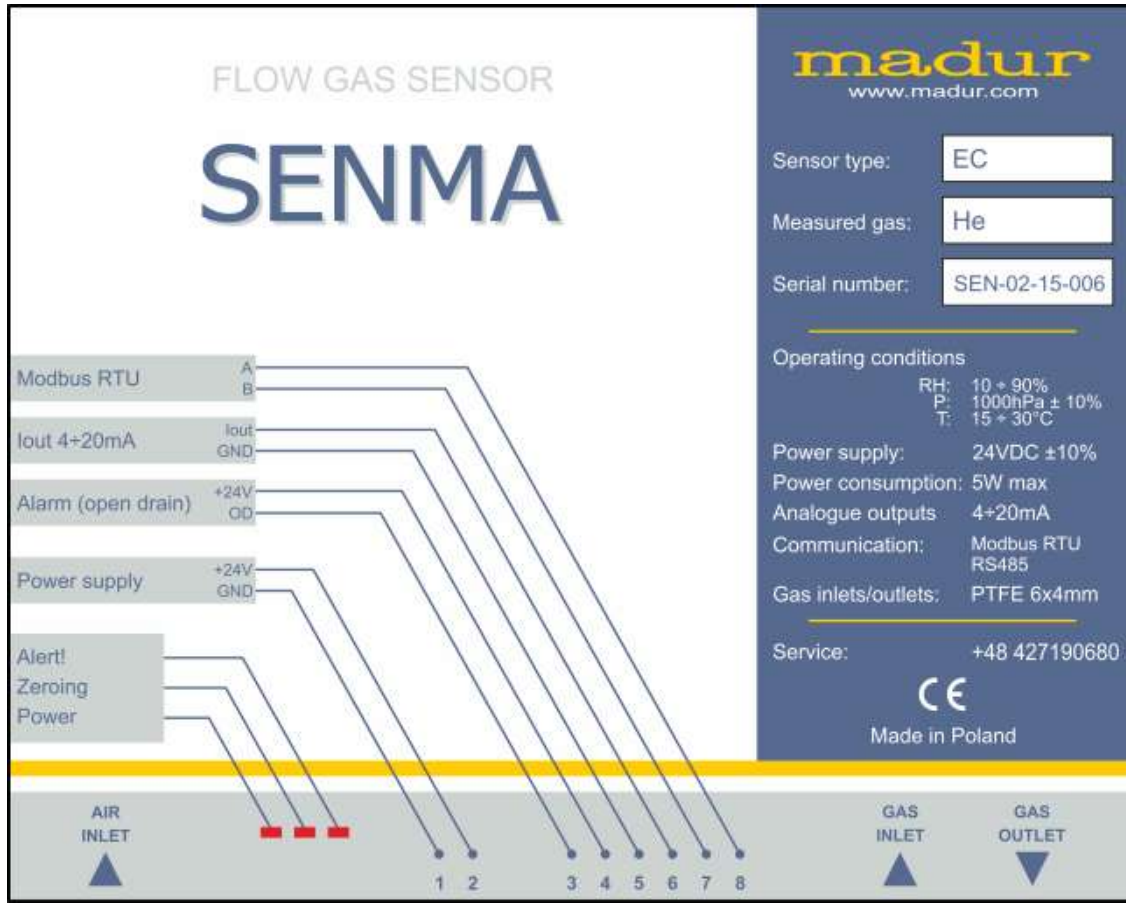

Drawing 9. Senma – front panel

4. SENMA PC PROGRAM

Madur.exe is a PC program that allows to change sensor's settings and to perform calibration -

http://www.madur.com/data/download/00_common/software/mamos%20%20-%20software%20v13.1.5%20ml.zip

Communication with sensor is done via USB-RS485 adapter, like one presented in the picture below:



Drawing 10. CH340 communication adapter (RS485-USB)

Connect adapter using 2-wire cable (length up to hundreds of meters):

Senma terminal 8 (RS485 A / Modbus RTU A) ↔ CH340 adapter terminal A

Senma terminal 7 (RS485 B / Modbus RTU B) ↔ CH340 adapter terminal B

Download and install CH340 windows drivers from [this location](#).

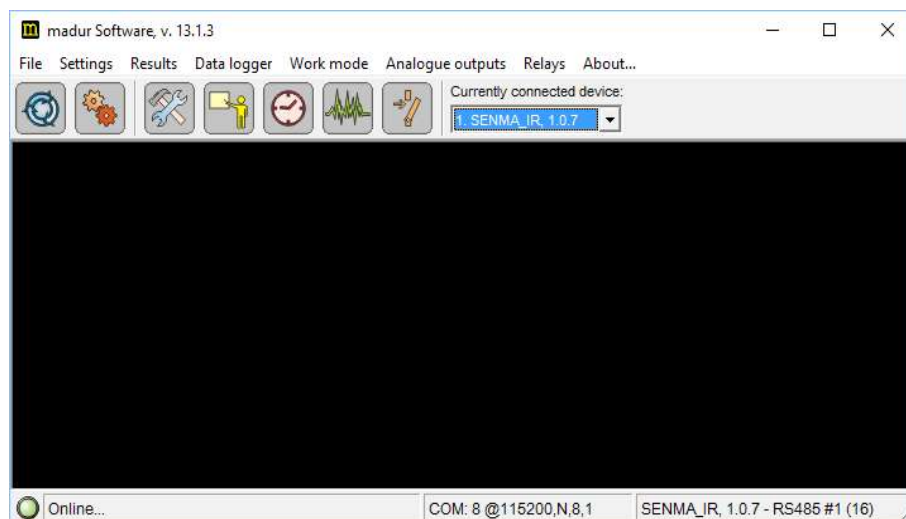

Drawing 11. PC program – main window

With help of software user can (among others):

- Select work cycle
- Adjust settings of analogue output
- Adjust setting of LED and alarm

4.1. Work cycles

Drawing 12. Program PC – tryby pracy – praca cykliczna

By default (factory setting) Senma works in 12-hours-cycle. It means that 15-minutes Ventilation is performed twice a day. The first Ventilation with zeroing starts at 6.00 AM the next one at 6.00 PM. Drawing 12. Shows the described settings.

These settings (length of each phase, frequency of occurrence) can be freely changed in the program.

User can change:

1. duration of the entire cycle
2. duration of Ventilation
3. duration of Measurements
4. moment of the first ventilation and zeroing
5. work mode:
 - a) Cyclic work mode (basic selection)
 - b) Measurements according to scheduler – user can define up to 24 moments during a day when measurement cycle will start. E.g. measurements that will last for 2h with starting point 8.13 and 15.24 (Ventilation that proceeds Measurements must be considered):

Work mode

Duration of cycle's phases

hh:mm:ss

Ends in

Phase: 'Ventilation' 00:15:00

Phase: 'Infusion' 00:01:00

Phase: 'First zeroing' 00:02:00

Phase: 'Measurement' 02:00:00

Phase: 'Warm-up' 00:15:00

Work mode

Measurements according to scheduler

Scheduler

1.	<input checked="" type="checkbox"/>	07:58:00	13.	<input type="checkbox"/>	00:00:00
2.	<input checked="" type="checkbox"/>	15:09:00	14.	<input type="checkbox"/>	00:00:00
3.	<input type="checkbox"/>	00:00:00	15.	<input type="checkbox"/>	00:00:00
4.	<input type="checkbox"/>	00:00:00	16.	<input type="checkbox"/>	00:00:00
5.	<input type="checkbox"/>	00:00:00	17.	<input type="checkbox"/>	00:00:00
6.	<input type="checkbox"/>	00:00:00	18.	<input type="checkbox"/>	00:00:00
7.	<input type="checkbox"/>	00:00:00	19.	<input type="checkbox"/>	00:00:00
8.	<input type="checkbox"/>	00:00:00	20.	<input type="checkbox"/>	00:00:00
9.	<input type="checkbox"/>	00:00:00	21.	<input type="checkbox"/>	00:00:00
10.	<input type="checkbox"/>	00:00:00	22.	<input type="checkbox"/>	00:00:00
11.	<input type="checkbox"/>	00:00:00	23.	<input type="checkbox"/>	00:00:00
12.	<input type="checkbox"/>	00:00:00	24.	<input type="checkbox"/>	00:00:00

Input IN1 Input IN2 Input IN3 Input IN4

No action
 Restart measurement cycle
 Terminate measurement cycle

The input does not affect measurement cycle.

0 1 2 3 4 5 6 7 8 9 10 11 12 13 14 15 16 17 18 19 20 21 22 23 0

1 2

Stand-by Warm-up Ventilation Measurement

Preview Save Default Restart cycle Terminate cycle Close

Drawing 13. PC Program – Work modes – Measurements according to scheduler

- c) Measurements triggered by digital input – the start and/or the end of measurement cycle is triggered with electrical signal provided to the sensor's digital input (its terminal is not installed by default)
- d) Long-term, monthly-cyclic mode – allows to perform long lasting measurements (month) without Ventilation and Zeroing

ATTENTION: Because the accuracy of measurements (especially measurements of low concentrations) is highly depended on the frequency of zeroings, this work mode can be selected only conditionally.

- e) Long-term mode with adjustable length (1-30 days) – similar to the aforesaid, except that the Ventilation with Zeroing is repeated at a specified number of days.

4.2. Analogue outputs

Sensor is equipped with one current analogue output (4÷20ma), that, by default, represents signal from gas sensor (optionally, it can be mapped to e.g. atmospheric pressure sensor, differential pressure sensor – flow through the sensor).

To the outputs max and min signals any value from sensor's measurement range can be assigned.

In example in Drawing 14. 10% of sensor's reading was assigned to the output's min (4mA). And 15% of sensor reading to output's max.

In this case, when gas concentration measured by sensor will be in range 0÷10%, output will “show” 4mA. For concentrations in range 10÷15% output will show a proportional signal from range 4÷20mA (e.g. Gas=12,5% → Iout=12mA). For concentrations above 15% output will “show” 20mA.

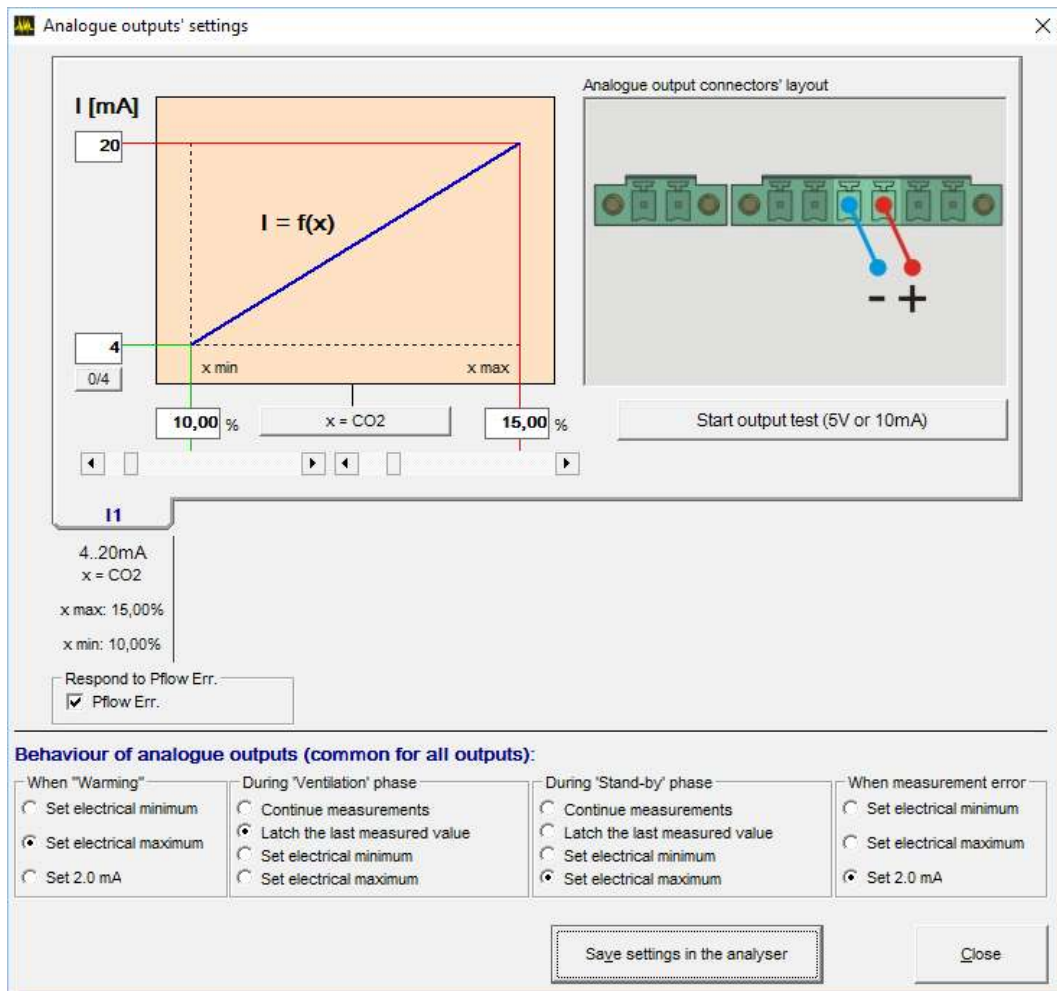

Drawing 14. PC program Program PC – analogue output

Drawing in the program's window presents terminal of analogue output. Below the drawing, there is a TEST button, that allows to verify the work of analogue outputs (when test is enabled output will “show” 10mA)

Besides adjusting the outputs range, one can also define behaviour of outputs when sensor is not in Measurements phase, or when error occurs.

During Ventilation, Standby, Warming, error output can be set to:

- show max value– 20mA
- show min value – 4mA
- show value below range– 2mA (e.g. to report sensor's error)
- continue measurements – during ventilation, electromagnetic valve is set to the source of fresh-air. If, during measurements, sensor was showing non-zero results, then during ventilations those will start to decrease – signal on analogue output will also start to drop down to minimum (4mA)
- latch the last measured value = keep the last value from measurement phase throughout the entire ventilation

Sensor is equipped with differential pressure sensor, that allows to control a flow in the gas path (patency of gas path). Sensor may warn if the flow drops below a threshold value. In this case thick Pflow Err checkbox – if pressure drops too low, analogue output will behave as in Error occurrence.

4.3. Relay outputs (alarms)

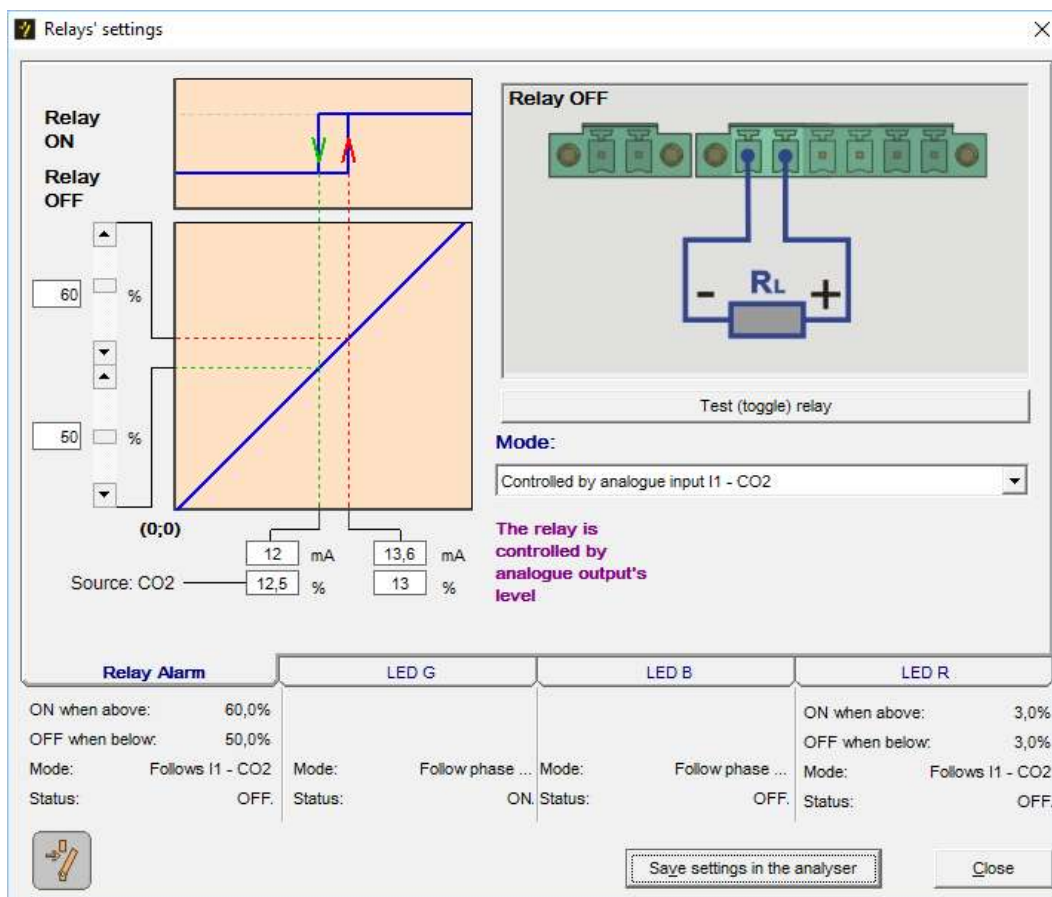

Drawing 15. PC Program – relay outputs (ALARM)

Sensor is equipped with one open-drain output, that can be used for connecting an alarm.

Available relay work modes:

1. controlled by analogue output I1
Relay is turned on / off (with hysteresis) when threshold values on analogue output (coupled with relay) are exceeded..
In example in Drawing 15. analogue output is set Gas=10%→Iout=4mA, Gas=15%→Iout=20mA. Alarm output will be turned on, when concentration of gas exceeds 13% (13,6mA on analogue output). Alarm will be turned off when gas concentration drops below 12,5% (12mA)
2. controlled by analogue output I1 – Inversion.
Work principle as in point 1. but with reversed logic, i.e. alarm is turned on when concentration drops below 13%, alarm turned off when concentration rises above 12,5%
3. Follow digital input IN1÷IN4 / Follow digital input IN-1÷IN4 – Inversion
Alarm is turned on (turned off for the Inversion) when the selected digital input IN1÷IN4 is high.
Alarm is turned off (turned on for Inversion) when the selected digital input IN1÷IN4 is low.

4. Follow phase

Alarm jest turned on, when a selected work phase is in progress.

Besides the adjustment of open-drain output, it is also possible to define the behaviour of LED (according to the described above schema).

Default settings of LED behaviour:

- green: informs that sensor is working → Follow phase (every option is selected)
- blue: informs when sensor is ventilating → Follow phase: (Ventilation and FirstZeroing, Infusion)
- red: signalises error → controlled by analogue output (threshold levels may be different than for open-drain relay)

5. MODBUS COMMUNICATION

Sensor SENMA has implemented MODBUS communication to work with industrial PLCs.

5.1. General parameters

Command in RTU format from master to slave	Answer message in RTU format from slave to master
START BREAK	START BREAK
minimum of 3.5 x time for single character transmission	minimum of 3.5 × time for single character transmission
ADDRESS of the receiver	ADDRESS of the slave device
1 byte	1 byte
value 0-240	value 0-240
FUNCTION CODE	FUNCTION CODE
1 byte	1 byte
indicates the function code	indicates the function code
DATA REGION	DATA REGION
n x 1 byte	n × 1 byte
CRC (checksum)	DATA
2 bytes	n × 1 byte
END BREAK	CRC (checksum)
minimum of 3.5 x time for single character transmission	2 bytes
	END BREAK
	minimum of 3.5 × time for single character transmission

Maximal length of communicate (with address and CRC) – 256 bytes (for SENMA 128 bytes only)

Silence longer than 1.5 characters resets the incoming buffer.

5.2. Type of data available via modbus

5.2.1. Coils – read/write one bit data

Coils in Senma are provided and supported, though their settings have no external consequences. It is possible to write/read them and they are stored after power down.

Address	Name	Description
#1001	Coil1	For future use
#1002	Coil2	For future use
#1003	Coil3	For future use
#1004	Coil4	For future use
#1005	Coil5	For future use
#1006	Coil6	For future use
#1007	Coil7	For future use
#1008	Coil8	For future use
#1009	Coil9	For future use
#1010	Coil10	For future use
#1011	Coil11	For future use
#1012	Coil12	For future use
#1013	Coil13	For future use
#1014	Coil14	For future use
#1015	Coil15	For future use
#1016	Coil16	For future use

5.2.2. Discrete Inputs – read-only bit data

Discretes present temporary status of Sensors various components.

Address	Name	Description
#2001	Relay1	Relay #1 status (1=active)
#2002	Relay2	Relay #2 status (1=active)
#2003	Relay3	Relay #3 status (1=active)
#2004	Relay4	Relay #4 status (1=active)
#2005	In1	Status of digital input #1 (0/1 = Lo/Hi) – it is not routed to connector
#2006	In2	Status of digital input #2 (0/1 = Lo/Hi) – it is not routed to connector
#2007	In3	Status of digital input #3 (0/1 = Lo/Hi) – it is not routed to connector
#2008	In4	Status of digital input #4 (0/1 = Lo/Hi) – it is not routed to connector
#2009	Valve1	Valve #1 status (ventilation valve) 0 → inactive (measurements) 1 → active (ventilation)
#2010	Valve2	Valve #2 status - does not exist in Senma
#2011	PumpOn	Gas pump status: 0/1 = off/on
#2012	PresFlowError	Flow control indicator: 0/1 = flow incorrect/correct
#2013	IsRTC	Presence indicator for RTC clock: 0/1 = absent/present
#2014	IsPressFlow	Presence indicator for flow control sensor : 0/1 = absent/present
#2015	IsPressAbs	Presence indicator for atmospheric pressure sensor: 0/1 = absent/present
#2016	IsSwitch	Presence indicator for work knob selector: 0/1 = absent/present
#2017	IsHatelDisp	Presence indicator for LED display: 0/1 = absent/present
#2018	IsLCD0	Presence indicator for LCD display: 0/1 = absent/present
#2019	vacat1	for future use
#2020	vacat2	for future use

5.2.3. Holding registers – 2-byte read/write data

Address	Name	Description
#3001	MBOwnAddress	MSB: Modbus own address (default 247); LSB: address negation
#3002	FirstZeroingTimeHi	Moment of zeroing (clock time), BCD format: 0x00 hh
#3003	FirstZeroingTimeLo	Moment of zeroing (clock time), BCD format: mm ss
#3004	WarmingTimeHi	Duration of warm-up, BCD format: 0x00 hh
#3005	WarmingTimeLo	Duration of warm-up, BCD format: mm ss
#3006	CycleTimeHi	Duration of cycle, BCD format: 0x00 hh
#3007	CycleTimeLo	Duration of cycle, BCD format: mm ss
#3008	PurgingTimeHi	Duration of ventilation, BCD format: 0x00 hh
#3009	PurgingTimeLo	Duration of ventilation, BCD format: mm ss
#3010	MeasureTimeHi	Duration of measurements, BCD format: 0x00 hh
#3011	MeasureTimeLo	Duration of measurements, BCD format: mm ss
#3012	vacat	for future use

#3013	Rs485Mode	RS485 Work mode (00AAH = madur, 0055H = modbus, other = modbus)
#3014	PumpPWM	Pump setting; MSB – behaviour during work phases, LSB - PWM
#3015	Relay1Hi2Lo	Lower alarm threshold level
#3016	Relay1Lo2Hi	Higher alarm threshold level
#3017	ZeroCalibOrder	Zeroing/Calibration command – more information in chapter: 5.2.11
#3018	CalibrationGas	Gas concentration for 1-point calibration

5.2.4. Input registers – read-only 2-byte data



Address	Name	Description
#4001	MBResult0	Measurement result #0 (gas)
#4002	MBResult1	Measurement result #1 (internal temperature)
#4003	MBResult2	Measurement result #2 (pressure on flow sensor)
#4004	MBResult3	Measurement result #3 (pressure on flow sensor) Attention: Registers MBResultN returns value -32768, when there is no result or incorrect result
#4005	MBResultCode0	result code #0 (see: Results table)
#4006	MBResultCode1	result code #1 (see: Results table)
#4007	MBResultCode2	result code #2 (see: Results table)
#4008	MBResultCode3	result code #3 (see: Results table)
#4009	MBUnitDP0	unit code (MSB) and number of decimal places (LSB) in result #0
#4010	MBUnitDP1	unit code (MSB) and number of decimal places (LSB) in result #1
#4011	MBUnitDP2	unit code (MSB) and number of decimal places (LSB) in result #2
#4012	MBUnitDP3	unit code (MSB) and number of decimal places (LSB) in result #3
#4013	MBAnaoutU	Voltage on analogue output U in [mV] (does not exist in Senma)
#4014	MBAnaoutI	Current on analogue output I in [uA]
#4015	MBAnaOutCodeU	result code on voltage output (does not exist in Senma)
#4016	MBAnaOutCodeI	result code on current output (see: Results table)
#4017	MBRTCDateHi	Date from RTC clock: 2 bytes in BCD format - YY YY
#4018	MBRTCDateLo	Date from RTC clock: 2 bytes in BCD format - MM DD
#4019	MBRTCTimeHi	Time from RTC clock: 2 bytes in BCD format - 00 HH
#4020	MBRTCTimeLo	Time from RTC clock: 2 bytes in BCD format - mm SS
#4021	MBStatus	Device status (work phase) (see: Table – work phases)
#4022	MBFirmwareVer	Firmware version: MSB = VersionBig, LSB = VersionSmall*16 + Revision
#4023	MBPhaseTimerHi	Time since the beginning of current phase: 2 bytes in BCD format - 00 HH
#4024	MBPhaseTimerLo	Time since the beginning of current phase: 2 bytes in BCD format - mm SS
#4025	MBSensorRangeMin	Minimum for sensors measurement range
#4026	MBSensorRangeMax	Maximum for sensors measurement range
#4027	MBSensorType0	MSB – type of gas sensor used in device LSB - model of gas sensor
#4028	MBDevice	Device type (see: Device table)
#4029	MBSerialNoHi	Serial number (two older bytes)

#4030	MBSerialNoLo	Serial number (two younger bytes)
#4031	MBAnaOutUminVoltage	Electrical minimum for output U [mV] (does not exist in Senma)
#4032	MBAnaOutUmaxVoltage	Electrical maximum for output U [mV] (does not exist in Senma)
#4033	MBAnaOutIminCurrent	Electrical minimum for output I [uA]
#4034	MBAnaOutImaxCurrent	Electrical maximum for output I [uA]
#4035	MBAnaOutUMinResult	Result corresponding to the U output's minimum (does not exist in Senma)
#4036	MBAnaOutUMaxResult	Result corresponding to the U output's maximum (does not exist in Senma)
#4037	MBAnaOutIminResult	Result corresponding to the I output's minimum
#4038	MBAnaOutImaxResult	Result corresponding to the I output's maximum
#4039	MBRelay21Src	MSB – stimulation source for Relay2, LSB – stimulation source for Relay1 (see: Table - stimulation source for relays)
#4040	MBRelay43Src	MSB – stimulation source for Relay4, LSB – stimulation source for Relay3 (see: Table - stimulation source for relays)

5.2.5. Device table

Code	Name	Description
28H	Hatel	madir2015, version Hatel (sensor IR one-channel)
29H	SenmaIR	madir2015, version Senma (sensor IR one-channel)
2AH	SenmaElch	madir2015, version Senma (sensor elchem)
2BH	SenmaO2	madir2015, version Senma (sensor O2 elchem)
2CH	SenmaTCD	madir2015, version Senma (sensor TCD)
2DH	SenmaVOC	madir2015, version Senma (sensor VOC)
2EH	SenmaO2MOX	madir2015, version Senma (sensor O2 MOX)

5.2.6. Table - stimulation source for relays

Code	RelayN Action
1	Follow the output AnalogOut I1 
8	Follow ~In1 → relay is on when In1 is Lo
9	Follow ~In2 → relay is on when In2 is Lo
10	Follow ~In3 → relay is on when In3 is Lo
11	Follow ~In4 → relay is on when In4 is Lo
12	Follow phase → according to byte RelayNBehavior
128+ 1	Follow the output with inversion 
128+ 8	Follow ~In1 → relay is off when In1 is Hi
128+ 9	Follow ~In2 → relay is off when In2 is Hi
128+10	Follow ~In3 → relay is off when In3 is Hi
128+11	Follow ~In4 → relay is off when In4 is Hi
others	Off – relay is constantly off

5.2.7. Results table

Kody wyników są dwubajtowe

Main code MSB	Supl. code LSB	Type of result	
0	0	O2	volume concentration
1	0	CO2	volume concentration
2	0	CH4	volume concentration
3	0	CO	volume concentration
4	0	NO	volume concentration
5	0	NO2	volume concentration
6	0	NOx	volume concentration
7	0	SO2	volume concentration
8	0	H2S	volume concentration
9	N	X	volume concentration (special gas from Special gas table)
10	N	Y	volume concentration (special gas from Special gas table)
11	N	Z	volume concentration (special gas from Special gas table)
12	0	---	does not occur
13	0	---	does not occur
14	0	PumpFlow	Gas flow in sensor;s gas path sensora
15	0	PressAbs	Atmospheric pressure
16	0	PressDif	Differential pressure
17	0	Tamb	Ambient temperature
18	0	Tgas	Gas temperature
19	0	T3	Additional temperature #3
20	0	T4	Additional temperature #4
21	0	SL	Stack loss
22	0	Tint	Internal temperature
23	0	Eta	Combustion efficiency
24	0	Lam	Excess air coefficient
25	0	Flow	Gas flow velocity
26	0	Hum	Relative humidity
27	0	CH4mg	mass concentration @ STP
28	0	COmg	mass concentration @ STP
29	0	NOmg	mass concentration @ STP
30	0	NO2mg	mass concentration @ STP
31	0	NOxmg	mass concentration @ STP
32	0	SO2mg	mass concentration @ STP
33	0	H2Smg	mass concentration @ STP
34	N	Xmg	mass concentration (special gas from Special gas table)
35	N	Ymg	mass concentration (special gas from Special gas table)
36	N	Zmg	mass concentration (special gas from Special gas table)

37	0	---	does not occur
38	0	---	does not occur
39	0	UI0	current / voltage at analogue input #1
40	0	UI1	current / voltage at analogue input #2
41	0	UI2	current / voltage at analogue input #3
42	0	UI3	current / voltage at analogue input #4
43	0	UI4	current / voltage at analogue input #5
44	0	UI5	current / voltage at analogue input #6
45	0	UI6	current / voltage at analogue input #7
46	0	UI7	current / voltage at analogue input #8
47	0	Ext1	External value measured with analogue input
48	0	Ext2	External value measured with analogue input
49	0	---	does not occur
50	0	---	does not occur
51	0	CH4rel	relative mass concentration
52	0	COrel	relative mass concentration
53	0	NOrel	relative mass concentration
54	0	NO2rel	relative mass concentration
55	0	NOxrel	relative mass concentration
56	0	SO2rel	relative mass concentration
57	0	H2Srel	relative mass concentration
58	N	Xrel	relative mass concentration (special gas from Special gas table)
59	N	Yrel	relative mass concentration (special gas from Special gas table)
60	N	Zrel	relative mass concentration (special gas from Special gas table)
61	0	---	does not occur
62	0	---	does not occur
63	0	MediumPress	Pressure of measured gas
64	x	None	NULL

5.2.8. Special gas table

N	Type of gas	Type of sensor
14	H2	electrochemical
15	NH3	electrochemical
16	Cl2	electrochemical
17	HCl	electrochemical
32	N2O	NDIR
34	CHF3	NDIR
43	VOC	PID
44	H2	TCD
45	HCHO	NDIR
46	SF6	NDIR

47	CF4	NDIR
18	BF3	electrochemical
19	BCl3	electrochemical
50	SiH4	electrochemical
51	SiH2Cl2	electrochemical

5.2.9. Units table

N	Unit
0	[ppm]
1	[%]
2	[°C]
3	[°F]
4	[mg/m3]
5	[g/GJ]
6	[hPa]
7	[Pa]
8	[mmH2O]
9	[inH2O]
10	[m/s]
11	[mV]
12	[V]
13	[mA]
14	[A]
15	[] - unitless
16	[g/m3]
17	[l/h]

5.2.10. Table – work phases

N	Name	Description
0	FazaWarming	Initial phase during which thermal conditions stabilise; executed only ones after device start-up
1	FazaZeroing	Ventilation with zeroing executed at the beginning of every measurement cycle; is to calibrate signal of O2 sensor and to zero signals of other gas sensors
2	FazaMeasuring	Essential work phase executed in every cycle
3	FazaBeforeStandby	Occurs before sensor goes to standby; is to remove residues of measured gas from gas path and sensors
4	FazaStandby	Resting, device does not perform and usable measurements but it is ready to start them immediately (right after Ventilation)
5	FazaDisplayTest	Initial phase (lasts few seconds after device is powered on)
6	FazaDisplayIdentification	Initial phase (lasts few seconds after device is powered on)
7	FazaFirstZeroing	The first zeroing of device; occurs directly after Warming phase

8	FazaAfterZeroing	Initial period of measurement phase (infusion of gas = infusion of results) Measurements are performed, but the results are still not reliable.
---	------------------	--

5.2.11. Zeroing and span calibration via MODBUS

Register	Value	Description
3017	0000	Neutral value, it is to delete previous value
3017	0001	Command: Zeroing
3017	0002	Command: Remove zeroing
3017	0003	Command: Calibrate for a given gas (concentration of calibration gas must be previously provided to register 3018)
3017	0004	Command: Restore factory calibration
3017	1001	Positive – zeroing was done
3017	1002	Positive – remove zeroing was done
3017	1003	Positive – calibration at given gas was done
3017	1004	Positive – restore factory calibration was done
3017	-0001	Negative – zeroing was not done
3017	-0002	Negative – remove zeroing was not done
3017	-0003	Negative – calibration was not done
3017	-0004	Negative – restore factory calibration was not done
3018	XXXXX	Integer – concentration of calibration gas in a form depended on sensor's resolution (number of decimal points) – more information and examples are provided below.

Each type of gas sensor used by madur (electrochemical, IR, TCD, PID) requires periodical ventilation with neutral gas and zeroing of zero signal.

Senma sensor can perform automatic ventilation – switches (with 3-way solenoid valve) from gas source to source of neutral gas (fresh air). After a specified time it performs zeroing of zero signal.

It is possible to disable sensor's ventilation system and to provide it via external devices.

5.2.11.1. Sensor's zeroing procedure:

1. Feed the neutral gas to sensor for a specified time (recommend 15 min) in order to stabilise the zero signal.
2. To the register ZeroCalibOrder send Zeroing command = 0001 (see table above)
3. Read register ZeroCalibOrder to see if the zeroing was performed correctly (register ZeroCalibOrder value = 1001).

Besides zeroing of the sensor, ZeroCalibOrder register allows to:

- remove zeroing
- perform span calibration
- remove span calibration

5.2.11.2. Span calibration procedure

1. Span calibration should be proceeded with sensor's zeroing – 5.2.11.1

2. To the register CalibrationGas write the concentration of calibration gas. Because register is limited to 2 bytes, the maximal allowed value is 32768. For this reason, the correct value of calibration gas concentration is conditioned by sensor's precision – according to the examples given below.

Sensor's range	Precision – number of decimal places	Concentration of calibration gas	Correct value to write in the CalibrationGas register
5 %	0,001%	1,24% (=12.400 ppm)	1240
100 %	0,01%	25,5%	2550
20.000 ppm	1 ppm	304 ppm	304
100 ppm	0,1 ppm	50,5 ppm	505

3. Feed the calibration gas to sensor for specified time (minimal recommended = 15 min) – in order to stabilise the signal
4. To the register ZeroCalibOrder send the Calibration command = 0003 (see table above)
5. Read register ZeroCalibOrder to see if the calibration was performed correctly (register ZeroCalibOrder value = 1003).

6. TECHNICAL DATA AND OPERATIONAL INFORMATION

Work parameters:	
Temperature	10 ÷ 50°C
Relative humidity:	5 ÷ 90% (non-condensed)
Power supply:	13 ÷ 30 VDC (recommended 24VDC)
Maxximal power consumption:	10W
Analogue outputs:	0/4 ÷ 20mA
Digital outputs:	MODBUS 485 / RS485
Gas pump:	membrane, supply 12VDC, gas flow about 90l/h, loudness 70 dB
Ventilation valve	3-way, 12VDC
Gas ports:	Stainless steel, for tube PTFE 4x6mm
Gas path:	Tube PTFE 4x6mm
Electric connectors:	Type: Phoenix MCV 1,5/ 2-GF-5,08 (8A / 160V) Matting type (mounted on cable): Phoenix MC1.5/2-ST1F-5.08

REMARKS for proper OPERATION:

- All SNEMA sensors, independently from the type of gas detector, require for the correct work, periodical ventilation with neutral gas (that does not contain molecules of measured gas). Neutral gas can be fresh-air from the room's ventilating system. To the fresh-air inlet connect the 4x6 PTFE tube and placed it inside the room's ventilation. Alternatively, lead the tube outdoors. Frequency of ventilations has a direct influence on sensor's performance – accuracy of measurements (especially low concentrations). The minimal advised interval between zeroings: twice a day (every 12h)
- Manufacturer advises to perform technical inspection of device at least once a year: verification of measurement signals against reference gas. In case of signal divergnaces a full calibration of sensor must be performed.